

# *Mia Cucina*

KITCHENS BY TOWNGAS



# User Manual

## Built-in Microwave Oven with Grill CV25M

### Dear Customer

Thank you for choosing Mia Cucina products. These meticulously designed products, manufactured with the highest quality materials, have been carefully tested to satisfy your cooking needs. Please read and follow the following instructions that ensure correct operation and optimal performance.

### Contents

Precautions	P. 1
Specification	P. 1
Importance Safety Instructions	P. 2
Instructions for Utensils	P. 4
Introduction of Oven	P. 5
Set Up & Installation	P. 6
Cleaning & Maintenance	P. 8
Operating Instructions	P. 9
Trouble Shooting	P. 13

### Attention!

Read these instructions carefully before using your microwave oven, and keep it carefully. If you follow the instructions, your oven will provide you with many years of good service.

**SAVE THESE INSTRUCTIONS CAREFULLY**

## Precautions & Specification

### PRECAUTIONS TO AVOID POSSIBLE EXPOSURE TO EXCESSIVE MICROWAVE ENERGY

- a) Do not attempt to operate this oven with the door open since this can result in harmful exposure to microwave energy. It is important not to break or tamper with the safety interlocks.
- b) Do not place any object between the oven front face and the door or allow soil or cleaner residue to accumulate on sealing surfaces.
- c) **WARNING:** If door or door seals are damaged, the oven must not be operated until it has been repaired by a competent person.

#### Addendum

If the apparatus is not maintained in a good state of cleanliness, its surface could be degraded and affect the lifespan of the apparatus and lead to a dangerous situation.

#### Specification

Model:	CV25M-G
Rated Voltage:	220-240V ~50Hz
Rated Input Power (Microwave):	1450W
Rated Output Power (Microwave):	900W
Rated Input Power (Grill):	1000W
Oven Capacity:	25L
Turntable Diameter:	Ø315mm
External Dimensions:	595 x 399 x 388 mm
Net Weight:	Approx. 19 kg

# Important Safety Instructions

## READ CAREFULLY AND KEEP FOR FUTURE REFERENCE.

**WARNING: To reduce the risk of fire, electric shock, injury to persons or exposure to excessive microwave oven energy when using your appliance, follow basic precautions, including the followings:**

1. **WARNING:** Liquids and other foods must not be heated in sealed containers since they are liable to explode.
2. **WARNING:** It is hazardous for anyone other than a competent person to carry out any service or repair operation that involves the removal of a cover which gives protection against exposure to microwave energy.
3. This appliance can be used by children aged from 8 years and above and persons with reduced physical, sensory or mental capabilities or lack of experience and knowledge if they have been given supervision or instruction concerning use of the appliance in a safe way and understand the hazards involved. Children shall not play with the appliance. Cleaning and user maintenance shall not be made by children unless they are older than 8 and supervised.
4. Keep the appliance and its cord out of reach of children less than 8 years.
5. Only use utensils suitable for use in microwave ovens.
6. The oven should be cleaned regularly and any food deposits should be removed.
7. Read and follow the specific: "PRECAUTIONS TO AVOID POSSIBLE EXPOSURE TO EXCESSIVE MICROWAVE ENERGY".
8. When heating food in plastic or paper containers, keep an eye on the oven due to the possibility of ignition.
9. If smoke is emitted, switch off or unplug the appliance and keep the door closed in order to stifle any flames.
10. Do not overcook food.
11. Do not use the oven cavity for storage purposes. Do not store items, such as bread, cookies, etc. inside the oven.
12. Remove wire twist-ties and metal handles from paper or plastic containers/bags before placing them in the oven.
13. Install or locate this oven only in accordance with the installation instructions provided.
14. Eggs in the shell and whole hard-boiled eggs should not be heated in microwave ovens since they may explode, even after microwave heating has ended.
15. Use this appliance only for its intended uses as described in manual. Do not use corrosive chemicals or vapors. This oven is especially designed for residential usage. It is not designed for industrial or laboratory use.
16. This appliance is intended to be used in household and similar applications such as:
  - staff kitchen areas in shops, offices and other working environments;
  - by clients in hotels, motels and other residential type environments;
  - farm houses;
  - bed and breakfast type environments.
17. If the supply cord is damaged, it must be replaced by the manufacturer, its service agent or similarly qualified persons in order to avoid a hazard.
18. Do not store or use this appliance outdoors.
19. Do not use this oven near water, in a wet basement or near a swimming pool.
20. The temperature of accessible surfaces may be high when the appliance is operating. The surfaces are liable to get hot during use. Keep cord away from heated surface, and do not cover any events on the oven.
21. Do not let cord hang over edge of table or counter.
22. Failure to maintain the oven in a clean condition could lead to deterioration of the surface that could adversely affect the life of the appliance and possibly result in a hazardous situation.
23. The contents of feeding bottles and baby food jars shall be stirred or shaken and the temperature checked before consumption, in order to avoid burns.

## Important Safety Instructions

24. Microwave heating of beverages can result in delayed eruptive boiling, therefore care must be taken when handling the container.
25. The appliance is not intended for use by persons (including children) with reduced physical , sensory or mental capabilities, or lack of experience and knowledge, unless they have been given supervision or instruction concerning use of the appliance by a person responsible for their safety.
26. Children should be supervised to ensure that they do not play with the appliance.
27. The appliances are not intended to be operated by means of an external timer or separate remote-control system.
28. Accessible parts may become hot during use. Young children should be kept away.
29. Steam cleaner is not to be used.
30. During use the appliance becomes hot. Care should be taken to avoid touching heating elements inside the oven.
31. Only use the temperature probe recommended for this oven. (for ovens provided with a facility to use a temperature-sensing probe.)
32. **WARNING:** The appliance and its accessible parts become hot during use. Care should be taken to avoid touching heating elements. Children less than 8 years of age shall be kept away unless continuously supervised.
33. The microwave oven must be operated with the decorative door open. (for ovens with a decorative door.)
34. Surface of a storage cabinet can get hot.
35. Do not use harsh abrasive cleaners or sharp metal scrapers to clean the oven door glass since they can scratch the surface, which may result in shattering of the glass.
36. **WARNING:** Ensure that the appliance is switched off before replacing the lamp to avoid the possibility of electric shock.
37. The door or the outer surface may get hot when the appliance is operating.

### To Reduce the Risk of Injury to Persons Grounding Installation

#### **DANGER: Electric Shock Hazard**

Touching some of the internal components can cause serious personal injury or death. Do not disassemble this appliance.

#### **WARNING: Electric Shock Hazard**

Improper use of the grounding can result in electric shock. Do not plug into an outlet until appliance is properly installed and grounded. This appliance must be grounded. In the event of an electrical short circuit, grounding reduces the risk of electric shock by providing an escape wire for the electric current. This appliance is equipped with a cord having a grounding wire with a grounding plug. The plug must be plugged into an outlet that is properly installed and grounded.

Consult a qualified electrician or serviceman if the grounding instructions are not completely understood or if doubt exists as to whether the appliance is properly grounded. If it is necessary to use an extension cord , use only a 3-wire extension cord.

1. A short power-supply cord is provided to reduce the risks resulting from becoming entangled in or tripping over a longer cord.
2. If a long cord set or extension cord is used:
  - i. The marked electrical rating of the cord set or extension cord should be at least as great as the electrical rating of the appliance.
  - ii. The extension cord must be a grounding type 3-wire cord.
  - iii. The long cord should be arranged so that it will not drape over the counter top or table top where it can be pulled on by children or tripped over unintentionally.

# Instructions for Utensils

## Caution: Personal Injury Hazard

It is hazardous for anyone other than a competent person to carry out any service or repair operation that involves the removal of a cover which gives protection against exposure to microwave energy.

See the instructions on "Materials you can use in microwave oven or to be avoided in microwave oven." There may be certain non-metallic utensils that are not safe to use for microwaving. If in doubt, you can test the utensil in question following the procedure below.

- Utensil Test:**
1. Fill a microwave-safe container with 1 cup of cold water (250ml) along with the utensil in question.
  2. Cook on maximum power for 1 minute.
  3. Carefully feel the utensil. If the empty utensil is warm, do not use it for microwave cooking.
  4. Do not exceed 1 minute cooking time.

## Materials you can use in microwave oven

Utensils	Remarks
Aluminum foil	Shielding only. Small smooth pieces can be used to cover thin parts of meat or poultry to prevent overcooking. Arcing can occur if foil is too close to oven walls. The foil should be at least 1 inch (2.5cm) away from oven walls.
Browning dish	Follow manufacturer's instructions. The bottom of browning dish must be at least 3/16 inch (5mm) above the turntable. Incorrect usage may cause the turntable to break.
Dinnerware	Microwave-safe only. Follow manufacturer's instructions. Do not use cracked or chipped dishes.
Glass jars	Always remove lid. Use only to heat food until just warm. Most glass jars are not heat resistant and may break.
Glassware	Heat-resistant oven glassware only. Make sure there is no metallic trim. Do not use cracked or chipped dishes.
Oven cooking bags	Follow manufacturer's instructions. Do not close with metal tie. Make slits to allow steam to escape.
Paper plates and cups	Use for short-term cooking/warming only. Do not leave oven unattended while cooking.
Paper towels	Use to cover food for reheating and absorbing fat. Use with supervision for a short-term cooking only.
Parchment paper	Use as a cover to prevent splattering or a wrap for steaming.
Plastic	Microwave-safe only. Follow the manufacturer's instructions. Should be labelled "Microwave Safe". Some plastic containers soften, as the food inside gets hot. "Boiling bags" and tightly closed plastic bags should be slit, pierced or vented as directed by package.
Plastic wrap	Microwave-safe only. Use to cover food during cooking to retain moisture. Do not allow plastic wrap to touch food.
Thermometers	Microwave-safe only (meat and candy thermometers).
Wax paper	Use as a cover to prevent splattering and retain moisture.

## Materials to be avoided in microwave oven

Utensils	Remarks
Aluminum tray	May cause arcing. Transfer food into microwave-safe dish.
Food carton with metal handle	May cause arcing. Transfer food into microwave-safe dish.
Metal or metal-trimmed utensils	Metal shields the food from microwave energy. Metal trim may cause arcing
Metal twist ties	May cause arcing and could cause a fire in the oven.
Paper bags	May cause a fire in the oven.
Plastic foam	Plastic foam may melt or contaminate the liquid inside when exposed to high temperature.
Wood	Wood will dry out when used in the microwave oven and may split or crack.

# Introduction of Oven

## Control Panel

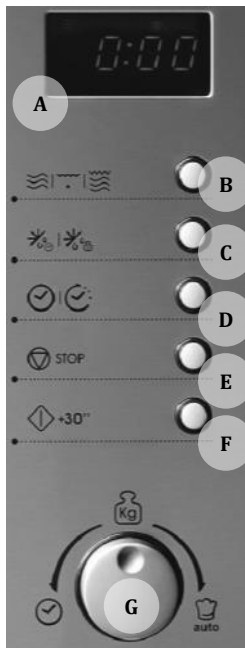

- |    |                       |                  |
|----|-----------------------|------------------|
| A. | Display               |                  |
| B. | Micro./Grill/Combi.   | Selection Button |
| C. | Weight/Time Defrost   | Selection Button |
| D. | Clock/Pre-set         | Selection Button |
| E. | Stop/Clear            | Selection Button |
| F. | Start/+30Sec./Confirm | Selection Button |
| G. | Selection Knob        |                  |

## Parts and Accessories

Remove the oven and all materials from the carton and oven cavity.

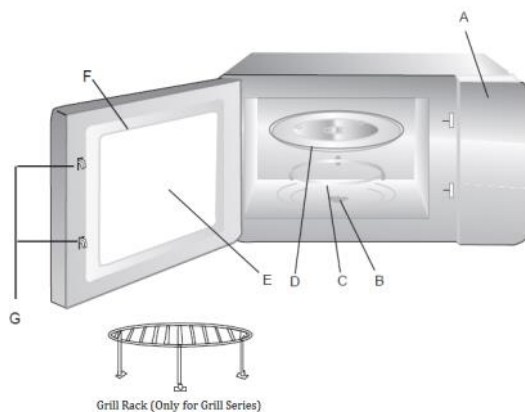

Your oven comes with the following accessories:

- Glass tray 1
- Turntable ring assembly 1
- Instruction Manual 1

- A. Control panel
- B. Turntable shaft
- C. Turntable ring assembly
- D. Glass tray
- E. Observation window
- F. Door assembly
- G. Safety interlock system

## Turntable Installation

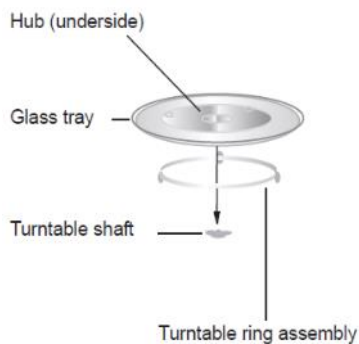

- a. Never place the glass tray upside down. The glass tray should never be restricted.
- b. Both glass tray and turntable ring assembly must always be used during cooking.
- c. All food and containers of food are always placed on the glass tray for cooking.
- d. If glass tray or turntable ring assembly cracks or breaks, contact your nearest authorized service center.



# Set Up & Installation Instructions

## PLEASE READ THE MANUAL CAREFULLY BEFORE INSTALLATION

### Please note:

#### Installation and Connection

1. This appliance is only intended for domestic use.
2. This oven is intended for built-in use only. It is not intended for counter-top use or for use inside a cupboard.
3. Please observe the special installation instructions.
4. The appliance can be installed in a 60cm wide wall-mounted cupboard (at least 50cm deep and 85cm off the floor).
5. The appliance is fitted with a plug and must only be connected to a properly installed earthed socket.
6. The mains voltage must correspond to the voltage specified on the rating plate.
7. The socket must be installed and connecting cable must only be replaced by a qualified electrician. If the plug is no longer to accessible following installation, an all-pole disconnecting device must be present on the installation side with a contact gap of at least 3mm.
8. Adapters, multi-way strips and extension leads must not be used. Overloading can result in a risk of fire.

#### Electrical Connection

The oven is fitted with a plug and must only be connected to a properly installed earthed socket. The socket must only be installed and the connecting cable must only be replaced by a qualified electrician, and in accordance with the appropriate regulations. If the plug is no longer accessible following installation, an all-pole isolating switch must be present on the installation side with a contact gap of at least 3 mm.

- The fitted cabinet must not have a back wall behind the appliance.
- Minimum installation height shall be 85 cm.
- Do not cover ventilation slots and suction holes.

**Note: Do not trap or bend the power cable.**

#### A. Built-in furniture

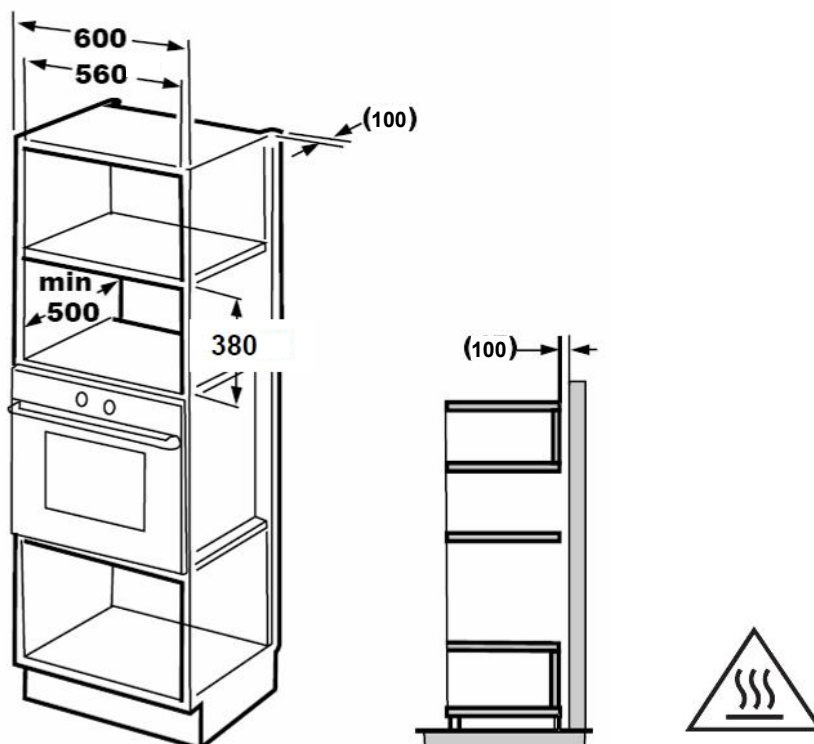

# Set Up & Installation

## B. Prepare the cabinet

1. Read the instruction on the BOTTOM CABINET TEMPLATE, put the template on the bottom plane of cabinet.

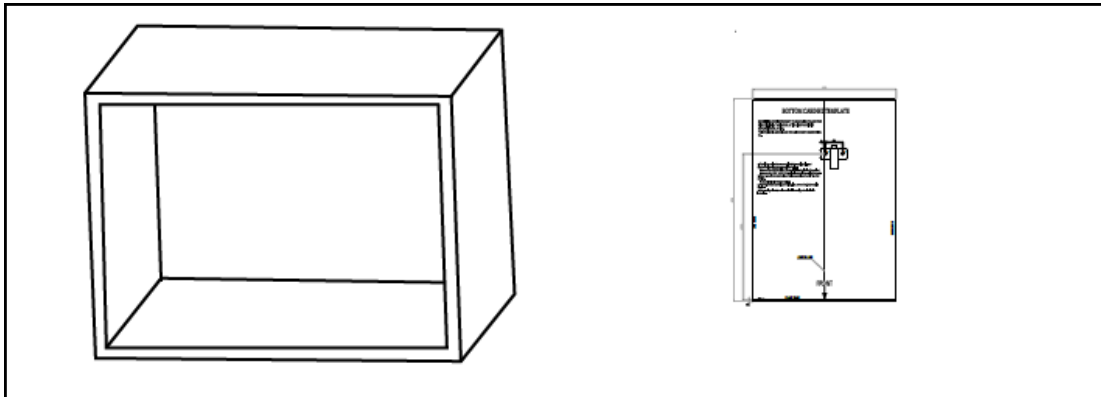

2. Make the marks on the bottom plane of cabinet according to marks "a" of the template.

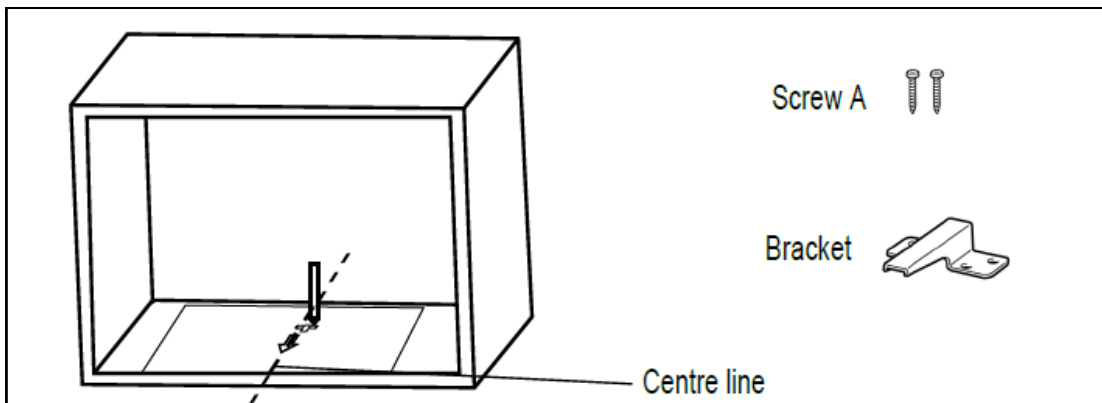

3. Remove the bottom cabinet template and fix the bracket with screw A.

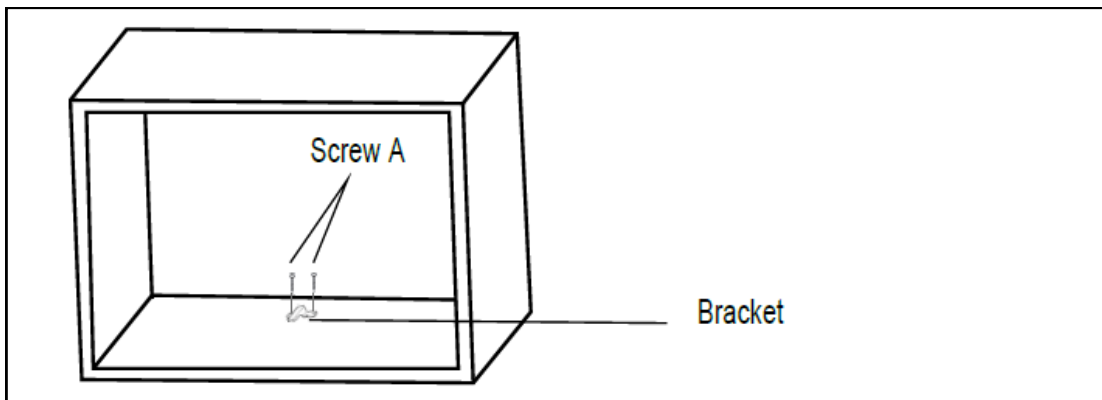

## Set Up & Installation

### C .Install the oven

4. Install the oven to the cabinet

- Make sure the back of the oven is locked by bracket.
- Do not trap or kink the power cord.

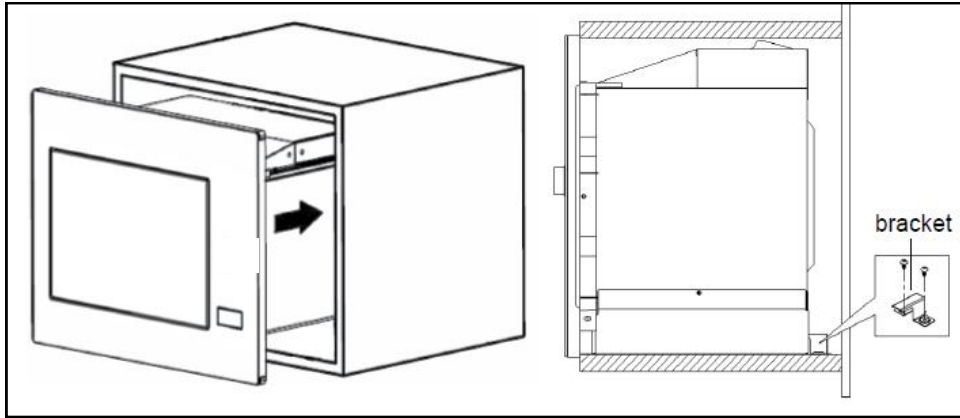

5. Open the door, fix the oven to the cabinet with Screw B, at the installation hole. Then fix the Trim-kit plastic cover to the installation hole.

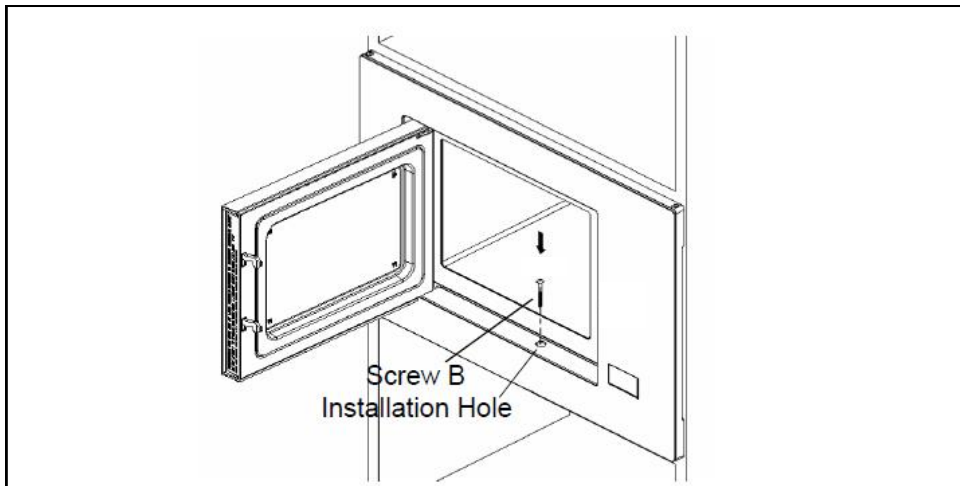

## Cleaning & Maintenance

**Be sure to unplug the appliance from the power supply.**

1. Clean the cavity of the oven after using with a slightly damp cloth.
2. Clean the accessories in the usual way in soapy water.
3. The door frame and seal and neighbouring parts must be cleaned carefully with a damp cloth when they are dirty.
4. Do not use harsh abrasive cleaners or sharp metal scrapers to clean the oven door glass since they can scratch the surface, which may result in shattering of the glass.
5. Cleaning Tip  
For easier cleaning of the cavity walls that the food cooked can touch:  
Place half a lemon in a bowl, add 300ml (1/2 pint) water and heat on 100% microwave power for 10 minutes. Wipe the oven clean using a soft, dry cloth.

# Operation Instructions

## 1. Clock Setting

When the microwave oven is electrified, the LED will display "0:00", buzzer will ring once.

- 1) Press "Clock/Pre-set" twice, the hour figures will flash.
- 2) Turn "Selection Knob" to adjust the hour figures, the input time should be within 0-23.
- 3) Press "Clock/Pre-set", the minute figures will flash.
- 4) Turn "Selection Knob" to adjust the minute figures, the input time should be within 0-59.
- 5) Press "Clock/Pre-set" to finish clock setting. ":" will flash, and the time will light.

- Note:
- 1) If the clock is not set, it would not function when powered.
  - 2) During the process of clock setting, if you press "Stop/Clear", the oven will go back to the previous status automatically.

## 2. Microwave Cooking

Press "Micro./Grill/Combi.", the LED will display "P100". Press "Micro./Grill/Combi." for times or Turn "Selection Knob" or to choose the power you want, and "P100", "P80", "P50", "P30" or "P10" will display for each added press. Then press "Start/+30Sec./Confirm" to confirm, and Turn "Selection Knob" to set cooking time from 0:05 to 95:00. Press "Start/+30Sec./Confirm" again to start cooking.

Example: If you want to use 80% microwave power to cook for 20 minutes, you can operate the oven as the following steps.

- 1) Press "Micro./Grill/Combi." once, the screen displays "P100".
- 2) Press "Micro./Grill/Combi." once again or turn "Selection Knob" to choose 80% microwave power.
- 3) Press "Start/+30Sec./Confirm" to confirm, and the screen displays "P80".
- 4) Turn "Selection Knob" to adjust the cooking time until the oven displays "20:00".
- 5) Press "Start/+30Sec./Confirm" to start cooking.

Note: The step quantities for the adjustment time of the coding switch are as follow:

0-1	min	5	seconds
1-5	min	10	seconds
5-10	min	30	seconds
10-30	min	1	minutes
30-95	min	5	minutes

"Micro/Grill/Combi." Order	Pad Instructions Display	Microwave Power	Grill Power
1	P100	100%	0%
2	P80	80%	0%
3	P50	50%	0%
4	P30	30%	0%
5	P10	10%	0%
6	G	0%	100%
7	C-1	55%	45%
8	C-2	36%	64%

## 3. Grill or Combi. Cooking

Press "Micro./Grill/Combi." once, "P100" displays and then press "Micro./Grill/Combi." for times or turn "Selection Knob" or to choose the power you want, and "G", "C-1" or "C-2" will display for each added press. Then press "Start/+30Sec./Confirm" to confirm, and turn "Selection Knob" to set cooking time from 0:05 to 95:00. Press "Start/+30Sec./Confirm" again to start cooking.

# Operation Instructions

Example: If you want to use 55% microwave power and 45% grill power (C-1) to cook for 10 minutes, you can operate the oven as the following steps.

- 1) Press "Micro./Grill/Combi." once, the screen displays "P100".
- 2) Press "Micro./Grill/Combi." again or turn "Selection Knob" to choose combi. 1 mode.
- 3) Press "Start/+30Sec./Confirm" to confirm, and the screen displays "C-1".
- 4) Turn "Selection Knob" to adjust the cooking time until the oven displays "10:00".
- 5) Press "Start/+30Sec./Confirm" to start cooking.

Note: If half the grill (grill only) time passes, the oven sounds twice, and this is normal. In order to have a better effect of grilling food, you should turn the food over, close the door, and then press "Start/+30Sec./Confirm" to continue cooking. If no operation, the oven will continue cooking.

## 4. Quick Start

- 1) In waiting state, press "Start/+30Sec./Confirm" to start 30 seconds cooking with 100% power, each added press will increase 30 seconds cooking time up to 95 minutes.
- 2) In microwave, grill, combi. cooking or time defrost state, each press of "Start/+30Sec./Confirm" can increase 30 seconds of cooking time.
- 3) In waiting state, turn "Selection Knob" to set cooking time with 100% microwave power, then press "Start/+30Sec./Confirm" to start cooking.

## 5. Defrost By Weight

- 1) Press "Weight/Time Defrost" once, and the oven will display "dEF1".
- 2) Turn "Selection Knob" to select the weight of food from 100g to 2000g.
- 3) Press "Start/+30Sec./Confirm" to start defrosting.

## 6. Defrost By Time

- 1) Press "Weight/Time Defrost" twice, and the oven will display "dEF2".
- 2) Turn "Selection Knob" to select the defrost time.
- 3) Press "Start/+30Sec./Confirm" to start defrosting.

## 7. Auto Menu

- 1) Turn "Selection Knob" to choose the menu, and "A-1" to "A-10" will display, which means pizza, meat, vegetable, pasta, potato, fish, beverage and popcorn.
- 2) Press "Start/+30Sec./Confirm" to confirm.
- 3) Turn "Selection Knob" to choose the default weight as the menu chart.
- 4) Press "Start/+30Sec./Confirm" to start cooking.

Example: If you want to use "Auto Menu" to cook fish for 350g.

- 1) Turn "Selection Knob" till "A-4" displays.
- 2) Press "Start/+30Sec./Confirm" to confirm.
- 3) Turn "Selection Knob" to select the weight of fish till "350" display.
- 4) Press "Start/+30Sec./Confirm" to start cooking.

# Operation Instructions

## The Menu Chart

Menu	Weight	Display
A-1 Pizza	200g	200
	400g	400
A-2 Potato	200g	200
	400g	400
	600g	600
A-3 Meat	250g	250
	350g	350
	450g	450
A-4 Fish	250g	250
	350g	350
	450g	450
A-5 Vegetable	200g	200
	300g	300
	400g	400
A-6 Beverage	1 cup (120ml)	1
	2 cups (240ml)	2
	3 cups (360ml)	3
A-7 Pasta	50g (with 450g cold water)	50
	100g (with 800g cold water)	100
A-8 Popcorn	50g	50
	100g	100
A-9 Chicken	200g	200
	400g	400
	600g	600
	800g	800
A-10 Reheat	200g	200
	400g	400
	600g	600

## 8. Kitchen Timer

- 1) Press "Clock/Pre-set" once, the hour figures will flash. Turn "Selection Knob" to adjust the hour.
- 2) Press "Clock/Pre-set" twice, the minute will flash. Turn "Selection Knob" to adjust the minute.
- 3) Press "Start/+30Sec./Confirm" to confirm setting.

When the kitchen time is reached, the buzzer will ring 5 times. If the clock has been set (24-hour system), LED will display the current time.

Note: The kitchen Time is different from 24-hour system. Kitchen Timer is a timer.

## 9. Pre-set Cooking

- 1) Set the clock first. (Consult the instruction of clock setting.)
- 2) Input the cooking program. Two stages can be set at most. Defrost should not be set as the cooking program.

# Operation Instructions

Example: If you want to cook with 80% microwave power for 7 minutes, operate it as the following:

- 1) Press "Micro./Grill/Combi." once, the screen displays "P100".
- 2) Press "Micro./Grill/Combi." once again or turn "Selection Knob" to choose 80% microwave power.
- 3) Press "Start/+30Sec./Confirm" to confirm, and the screen displays "P80".
- 4) Turn "Selection Knob" to adjust the cooking time until the oven displays "7:00".  
After the above steps, be careful not to press "Start/+30Sec./Confirm" to start cooking.
- 5) Press "Clock/Pre-set", the hour figures will flash.
- 6) Turn "Selection Knob" to adjust the hour figures, the input time should be within 0-23.
- 7) Press "Clock/Pre-set", the minute figures will flash.
- 8) Turn "Selection Knob" to adjust the minute figures, the input time should be within 0-59.
- 9) Press "Start/+30Sec./Confirm" to finish setting. If the door is closed, buzzer will ring twice when the time arrives, then cooking will start automatically.

## 10. Multi-section Cooking

At most 2 sections can be set for cooking. In multi-section cooking, if one section is defrosting, then defrosting shall be placed in the first section.

Example: If you want to defrost food for 5 minutes and then cook with 80% microwave power for 7 minutes, operate it as the following:

- 1) Press "Weight/Time Defrost" twice, and the oven will display "dEF2".
- 2) Turn "Selection Knob" to select the defrost time till "5:00" displays.
- 3) Press "Micro./Grill/Combi." once, the screen displays "P100".
- 4) Press "Micro./Grill/Combi." once again or turn "Selection Knob" to choose 80% microwave power.
- 5) Press "Start/+30Sec./Confirm" to confirm, and the screen displays "P80".
- 6) Turn "Selection Knob" to adjust the cooking time till the oven displays "7:00".
- 7) Press "Start/+30Sec./Confirm" to start cooking, and buzzer will sound once for the first section, defrosting time counts down; buzzer will sound once again entering the second cooking. When cooking finishes, buzzer sounds five times.

## 11. Inquiring Function

- 1) In states of microwave, grill and combination cooking, press "Micro./Grill/Combi.", the current power will be displayed for 3 seconds. After 3 seconds, the oven will turn back to the former state.
- 2) In cooking state, press "Clock/Pre-set" to inquire the time and the time will display for 3 seconds.
- 3) In pre-set state, press "Clock/Pre-set" to inquire the preset time and the preset time will display for 3 seconds.

## 12. Lock-out Function for Children

**Lock:** In waiting state, press "Stop/Clear" for 3 seconds, there will be a long beep time has been set, otherwise, the LED will display " [ : : ]".

**Lock quitting:** In locked state, press "Stop/Clear" for 3 seconds, there will be a long "beep" denoting that the lock is released.

## 13. Specification

- 1) "Start/+30Sec./Confirm" must be pressed to continue cooking if the door is opened during cooking.
- 2) Once the cooking programme has been set, "Start/+30Sec./Confirm" is not pressed in 1 minute. The current time will be displayed. The setting will be cancelled.
- 3) The buzzer sounds once by efficient press, inefficient press will be no response.
- 4) The buzzer will sound five times to remind you when cooking is finished.

# Trouble Shooting

## Normal

Microwave oven interfering TV reception	Radio and TV reception may be interfered when microwave oven operating. It is similar to the interference of small electrical appliances, like mixer, vacuum cleaner and electric fan. It is normal.
Dim oven light	In low power microwave cooking, oven light may become dim. It is normal.
Steam accumulating on door, hot air out of vents	In cooking, steam may come out of food. Most will get out from vents. But some may accumulate on cool place like oven door. It is normal.

## Forbidden

Oven started accidentally with no food in.	It is forbidden to run the unit without any food inside. It is very dangerous.
--	--

## Trouble

Problems	Possible Cause	Remedy
Oven cannot be started.	1) Power cord not plugged in tightly.	Unplug the appliance. Then, plug again after 10 seconds.
	2) Fuse blowing or circuit breaker works.	Replace fuse or reset circuit breaker (repair must be done by professional personnel with registrations according to the local regulation)
	3) Trouble with outlet.	Test outlet with other electrical appliances.
Oven does not heat.	4) Door not closed well.	Close door well.
Glass turntable makes noise when microwave oven operates.	5) Dirty roller rest on oven bottom.	Refer to "Maintenance of Microwave" to clean dirty parts.

## Customer Assistance Service

Carry out the above checks first before seeking assistance. If you cannot identify the cause of the operating abnormality, switch off the appliance (do not subject it to rough treatment) and contact the Assistance Service.

## Location of Product Serial Number

It is importance that you should inform to the Assistance Service with your product code and its serial number (a 16 character code which begins with the number 3). This can be found on the guarantee certificate or on the data plate located on the appliance.



**This appliance is marked according to the European directive 2002/96/EC on Waste Electrical and Electronic Equipment (WEEE). By ensuring this product is disposed of correctly, you will help prevent potential negative consequences for the environment and human health, which could otherwise be caused by inappropriate waste handling of this product.**

**The symbol on the product indicates that this product may not be treated as household waste. Instead it shall be handed over to the applicable collection point for the recycling of electrical and electronic equipment Disposal must be carried out in accordance with local environmental regulations for waste disposal.**

**For more detailed information about treatment, recovery and recycling of this product, please contact your local city office, your household waste disposal service or the shop where you purchased the product.**



# 使用說明書

## 嵌入式燒烤微波爐 CV25M

### 尊敬的客戶

多謝選用 Mia Cucina 的產品。本產品經精心設計，採用優質材料生產以及通過嚴謹測試，定能滿足您的烹飪需要。為確保爐具正確使用及維持最佳效能，請細閱及遵循以下說明。

### 目錄

注意事項	第 1 頁
技術規格	第 1 頁
重要安全指示	第 2 頁
容器指示	第 4 頁
微波爐簡介	第 5 頁
設置及安裝	第 6 頁
清潔及保養	第 8 頁
操作指示	第 9 頁
疑難排解	第 13 頁

### 注意!

在使用微波爐前，請仔細閱讀書內指示，並將說明書妥善保管。如果您按照指示操作，您的微波爐將為您提供多年的優質服務。

**請將說明書妥善保管**

# 注意事項及技術規格

## 避免暴露於過高微波能量機會的預防措施

- a. 切勿嘗試在微波爐門打開的情況下，運作微波爐，這有可能會使您暴露於微波能量之下。切勿打破或擅自改動安全聯動鎖。
- b. 切勿在微波爐的正面和門之間放置任何物件，或讓污垢、清潔劑殘留物，積聚在密封條的表面上。
- c. 警告：如微波爐門或其密封條受損，在未經具合資格的維修人員將其維修妥當前，切勿使用微波爐。

## 附錄

如未能良好保持微波爐的清潔狀況，微波爐表面可能會逐漸受損，並影響使用壽命，引致危險。

## 規格

型號：	CV25M-G
額定電壓：	220-240伏特 ~50赫茲
額定輸入功率：	1450瓦
額定輸出功率（微波）：	900瓦
額定輸出功率（燒烤）：	1000瓦
容量：	25升
轉盤直徑：	ø315毫米
微波爐尺寸：	595 x 399 x 388 毫米
淨重量：	約 19 公斤

# 重要安全指示

## 請仔細閱讀並保存本說明書以供日後參考

**警告：為避免於使用微波爐時導致火警、觸電、受傷或暴露於輸出的微波能量而引致風險，請遵守以下必須的預防措施：**

1. **警告：**不得在密封容器內加熱液體和其他食物，避免引起強烈的爆開。
2. **警告：**除合資格維修人員外，維修或拆除防止微波輻射洩漏的外殼，會對任何人構成極大危險。
3. 本產品可供8歲及以上的兒童，以及身體、感官或心理能力下降或缺乏經驗和知識的人士使用，但他們必須於有監護人士或指導人士在場及協助下使用，並瞭解潛在危險。兒童不得玩弄本產品。
4. 8歲以上的兒童，但他們必須於有監護人士或指導人士在場及協助下的情況下，可進行簡單清潔和保養。
5. 請將產品及其電源線放置在8歲或以下兒童接觸不到的地方。
6. 只可使用適合微波爐煮食的器皿。
7. 應定期清潔微波爐並清除食物殘渣。
8. 請閱讀並遵守「避免暴露於過高微波能量機會的預防措施」一節的內容。
9. 使用塑膠或紙質容器加熱食物時，由於有機會引起燃燒，請保持注意微波爐使用中的情況。
10. 如微波爐出現煙霧，請立即關閉電源或拔下電器插頭，並保持爐門關閉，以壓制火焰。
11. 請勿過度烹煮或加熱食物。
12. 請勿將微波爐內的煮食空間用於存儲用途。請勿在微波爐內的煮食空間內存放麵包、餅乾等物品。
13. 將紙質或塑膠容器/袋放入微波爐前，請將所有鐵線紮帶和金屬手柄等，從紙質或塑膠容器/袋中除去。
14. 請根據提供的安裝說明來安裝或放置本產品。
15. 帶殼雞蛋及原隻煮熟的雞蛋，不應使用微波爐加熱。因為即使在微波加熱結束後，它們也有可能爆開引起危險。
16. 本產品適合於家用和類似場合的使用，例如：
  - 可供商店、辦公室和其他辦公場所的員工廚房使用；
  - 可供酒店、汽車旅館和其他住宅場所的客戶使用；
  - 可供農舍使用；
  - 可供餐飲和住宿的旅館使用。
17. 如電源線損壞，必須由製造商、其維修代理或合資格的維修人員進行更換，以避免發生危險。
18. 切勿在戶外存放或使用本產品。
19. 切勿在靠近水源、潮濕的地牢或游泳池附近使用本產品。
20. 當產品運作時，可觸及地方的表面溫度可能很高。微波爐表面在使用期間容易變熱，請將電源線遠離受熱的表面，切勿在微波爐上方或道風口覆蓋任何物品。
21. 請勿讓電源線懸掛在桌子或櫃檯的邊緣。
22. 未能將微波爐保持清潔，可能會導致其表面破損，縮減微波爐的使用壽命，並可能導致危險情況發生。
23. 奶瓶及罐裝嬰兒食品加熱後，應進行攪拌或搖動，並在食用前檢查溫度，以免燙傷。
24. 對飲品進行微波加熱，有機會導致延遲的爆發沸騰，因此在處理時必須小心。

## 重要安全指示

25. 本產品不適合（包括兒童）身體、感官或精神能力下降或缺乏經驗和知識的人士（包括兒童）使用，除非負責其安全的人士，在他們使用產品時，進行現場的監督或指導。
26. 應監督兒童以確保他們不會把玩本產品。
27. 本產品不能通過外部計時器或獨立的遙控系統操作。
28. 可觸及的零件在使用過程中可能會變熱。應確保幼兒遠離本產品。
29. 請勿使用蒸汽清潔器。
30. 本產品在使用過程中會變熱。應小心避免接觸微波爐內的加熱配件。
31. 只可使用推薦用於本產品的溫度探針（對於安裝及可使用溫度探針設備的微波爐）。
32. **警告：**本產品及其可觸及零件在使用過程中會變熱。應注意避免接觸加熱配件。除非在成人密切監督下，8歲以下的兒童應遠離本產品。
33. 微波爐必須在打開櫥櫃門的情況下操作（對於安裝在帶門櫥櫃內的微波爐）。
34. 櫥櫃的表面可能會變熱。
35. 請勿使用粗糙的研磨劑或鋒利的金屬刮刀來清潔爐門玻璃，因為它們可能會劃損玻璃表面，導致玻璃碎裂。
36. **警告：**進行任何維修或更換爐內照明時，必須關閉電源供應，避免觸電。
37. 使用中的微波爐，爐門或微波爐外部可能會變熱。

### 必須連接地線，降低受傷的風險

#### 危險：觸電危險

觸摸某些內部零件，可能會導致嚴重的人身傷害或死亡。切勿拆開本產品。

#### 警告：觸電危險

不正確使用接地設備，可能會導致觸電。在產品正確安裝並接地之前，切勿插入電源插座。

本產品必須接地使用。在電流短路的情況下，接地為電流提供散逸通路，以減少觸電的風險。本產品配有帶接地插頭的接地電線。插頭必須插入正確安裝並已接地的插座。

如未能完全理解接地說明，或對產品是否正確安裝存在疑問，必須諮詢合資格的電工或維修人員。如需使用延長線，只能使用三芯延長線。

1. 使用長度較短的電源線以減少由纏結或被較長電源線絆倒而導致的風險。
2. 如使用長電線或延長線：
  - i. 電線或延長線所顯示額定功率，應與產品的額定功率相同；
  - ii. 延長線必須為接地式三芯電源線；
  - iii. 長電源線應適當放置，不應懸掛在櫃檯上或桌面上，它可能會被兒童拉扯或將別人意外絆倒。

# 容器指示

## 小心：人身傷害危險

除具有專業資格的維修人員外，任何人進行拆除防止微波能量洩漏的外殼的服務及維修操作，都非常危險。

請參閱「可用於微波爐或在微波爐中避免使用的物料」一節的指示。可能有一些無法安全用於微波的非金屬容器。如果有疑問，您可以按照以下步驟，測試該容器。

- 容器測試：**
1. 在一個能安全用於微波爐的容器中，注入1杯冷水（250ml）並放入接受測試的器皿。
  2. 使用最大火力加熱1分鐘。
  3. 小心用手觸摸容器。如果空的容器是溫熱的，則不要將其用於微波烹飪。
  4. 加熱時間不要超過1分鐘。

## 可用於微波爐的物料

容器	備註
鋁箔	只用於包裹食物。小片光滑的鋁箔，用於包裹肉類或家禽薄嫩的部分以防止過度烹煮。如果鋁箔太靠近爐壁，則可能會產生電弧。鋁箔應距離爐壁至少 1 英寸（2.5 釐米）。
烤盤	請遵照製造商的說明。烤盤的底部，必須至少比轉盤高 3/16 英寸（5 毫米）。使用不當，可能會導致轉盤破損。
餐具	只限微波爐安全專用。請遵守製造商的說明。請勿使用破裂或有缺口的碟子。
玻璃樽	必須取下蓋子。只可用於加熱食物至其剛剛溫暖的溫度。大多數玻璃樽不耐熱，可能會破裂。
玻璃容器	只可使用微波爐專用的耐熱玻璃容器。確保沒有金屬裝飾。請勿使用破裂或有缺口的玻璃容器。
微波爐專用袋	請遵守製造商的說明。請勿使用金屬綁帶密封。應留出縫隙，使蒸汽逸出。
紙碟和紙杯	只用於短時間烹飪/加熱。切勿在無人看管時進行烹飪。
紙巾	用於包裹食物以重新加熱並吸收脂肪。只用於短時間烹飪並需要看管。
羊皮紙	用作蓋罩防止水份飛濺或用作蒸汽保存用途。
塑膠	只限微波爐安全專用。請遵守製造商的說明。應有「微波爐安全」的標誌。由於容器內的食物變熱，一些塑膠容器會軟化。應按包裝說明對「蒸煮袋」和緊密封閉的塑膠袋，進行撕破、穿孔或洩氣操作。
保鮮紙	只限微波爐安全專用。在烹飪期間，用於包裹食物以保存水份。請勿讓保鮮紙接觸食物。
溫度計	只限微波爐安全專用（肉類和糖果類溫度計）。
蠟紙	用作蓋罩以防止水份飛濺和保持水份。

## 應避免在微波爐使用的物料

容器	備註
鋁盤	可能產生電弧。將食物轉移到微波爐專用的安全碟子中。
帶金屬手柄的食品紙盒	可能產生電弧。將食物轉移到微波爐專用的安全碟子中。
金屬或金屬裝飾的器皿	金屬會遮蓋食物使其免受微波能量。金屬裝飾條件可能產生電弧。
金屬縛帶	可能產生電弧並使微波爐起火。
紙袋	可能使微波爐起火。
發泡膠	當暴露於高溫時，發泡膠可能會熔化或污染盛載的飲品。
木材	木材在微波爐會變乾，並可能會裂開或爆裂。

# 微波爐簡介

## 控制面板

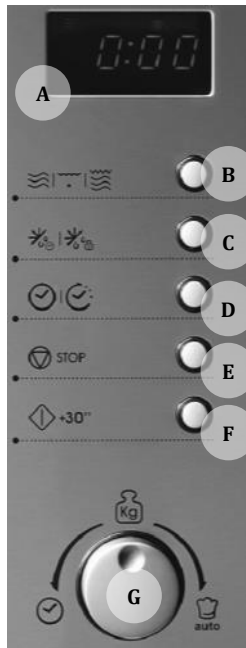

- A. 顯示器
- B. 微波/燒烤/混合 選擇按鍵
- C. 重量解凍/時間解凍 選擇按鍵
- D. 時鐘/預設 選擇按鍵
- E. 停止/取消 選擇按鍵
- F. 開始/+30秒/確定 選擇按鍵
- G. 選擇旋鈕

## 微波爐零件和配件名稱

從包裝箱取出微波爐，並從爐腔中取出所有配件。

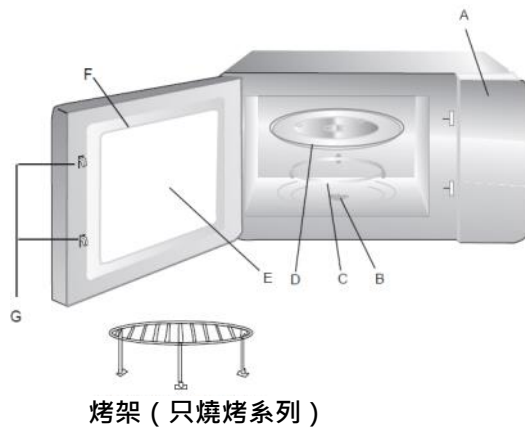

微波爐有以下配件：

- 玻璃托盤 1
- 轉盤環座 1
- 使用說明書 1

- A. 控制面板
- B. 轉盤承軸
- C. 轉盤環座
- D. 玻璃托盤
- E. 玻璃門
- F. 爐門組件
- G. 安全聯鎖系統

## 轉盤安裝



- a. 切勿將玻璃托盤倒置。玻璃托盤的轉動，不應受到限制。
- b. 烹飪時必須經常使用玻璃托盤和轉盤環座。
- c. 所有食物及食物容器，應經常放在玻璃托盤上進行烹飪。
- d. 如果玻璃托盤或轉盤環座破裂或斷裂，請與就近的授權維修中心聯絡。

# 設置及安裝說明

## 安裝前請仔細閱讀本用戶手冊

請注意：

### 安裝和連接

1. 本產品只可供家庭使用。
2. 本產品只可內嵌在櫥櫃中使用。不適用於枱面上或碗櫃內。
3. 請遵守指定的安裝說明。
4. 本產品可以安裝在60釐米寬的掛式櫥櫃（至少50釐米深，離地面85釐米）。
5. 本產品配有原裝電源插頭，必須連接到正確安裝的接地插座。
6. 電壓必須與資料牌上規定的電壓相符。
7. 必須安裝插座，並且由合資格的電器技工更換電線。如果安裝後無法觸及插頭，安裝一面，必須裝有全極中斷裝置，接觸空隙最少為3毫米。
8. 不得使用萬能插蘇、多孔插線板和延長線。電力負荷過重，可能會導致火災。

### 連接電源

本產品配有原裝插頭，只可連接到正確安裝的接地電源插座，並且只能由合格的技工按當地法例安裝接地電源插座及更換電綫。如果安裝後無法觸及插頭，接駁線路必須裝有全極電源開關，其接觸空隙最少為3毫米。

- 嵌入微波爐的櫥櫃，不得在微波爐後方設有背壁。
- 最少安裝高度為離地85釐米。
- 切勿遮擋通風槽口和進風口。

注意：請勿壓住或彎曲電源線。

### A. 嵌入式櫥櫃

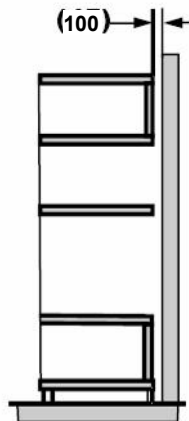
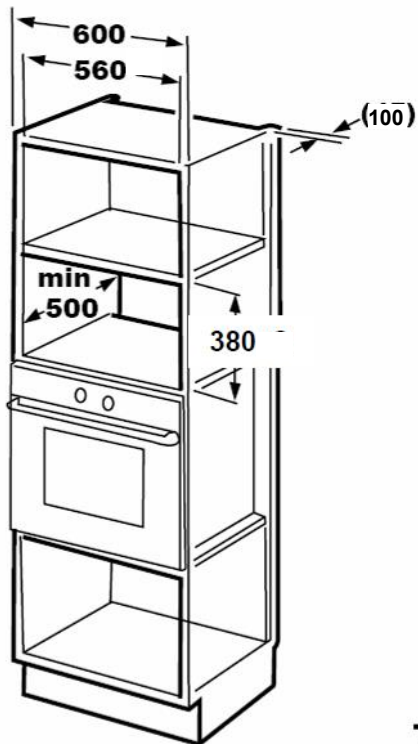

在操作期間，微波爐的接觸表面可能會發熱。

# 設置及安裝

## B. 準備櫥櫃安裝

1. 閱讀櫥櫃底部的安裝模板說明，將安裝模板放在櫥櫃的底板上。

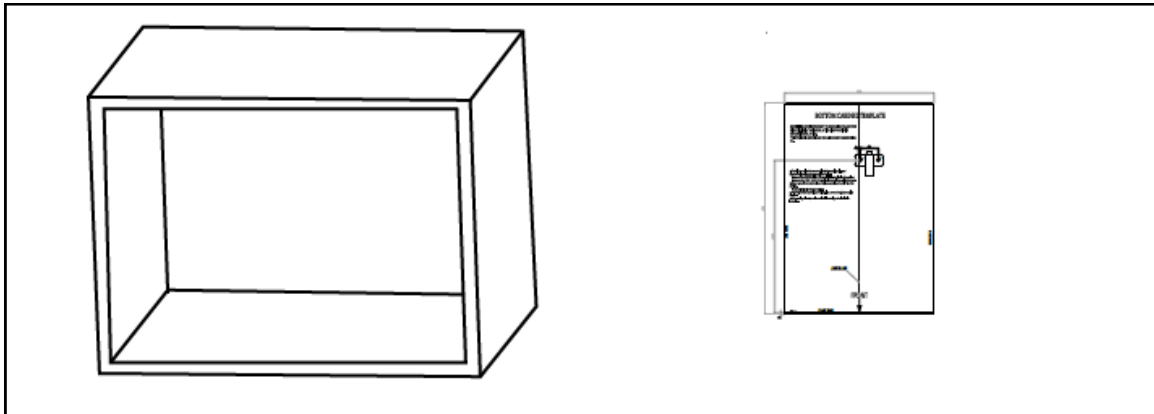

2. 根據安裝模板的標記「a」，在櫥櫃的底板上做標記

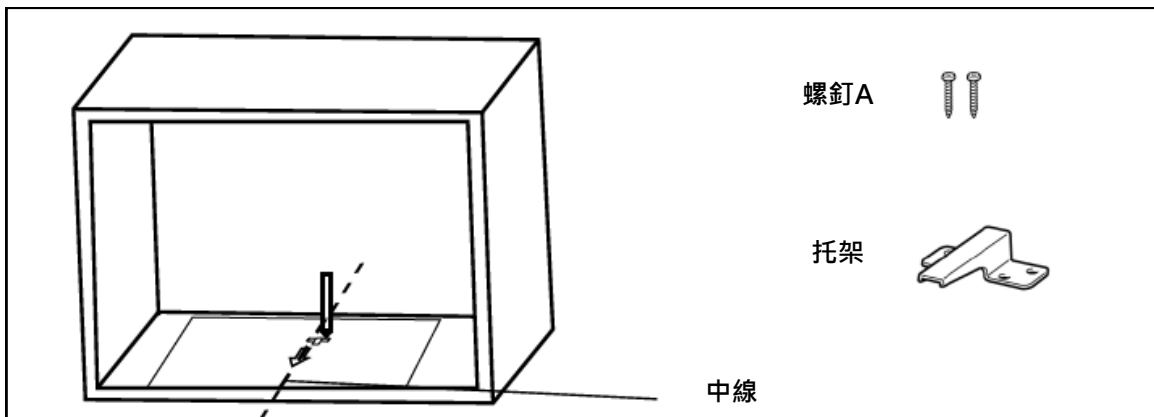

3. 移開安裝模板，並用螺釘A固定托架。

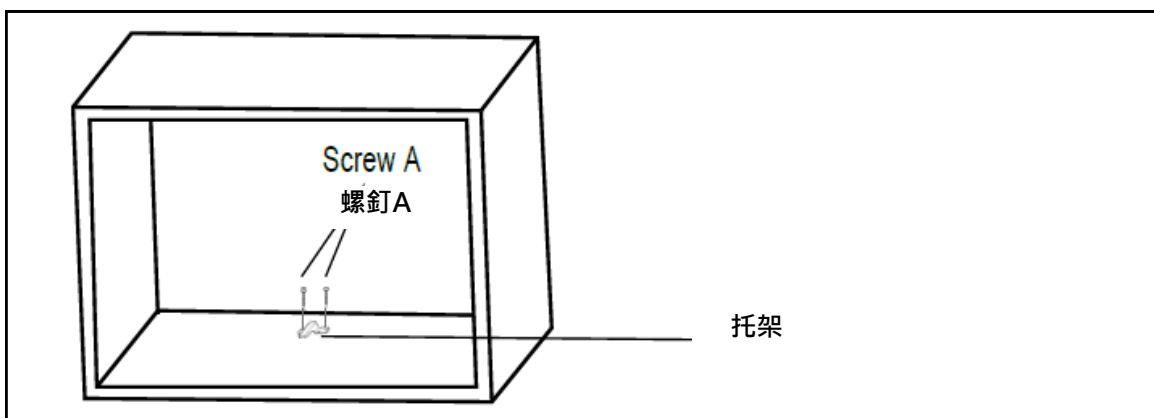



## 設置及安裝

### C. 微波爐安裝

4. 把微波爐安裝到櫥櫃內
  - 確保微波爐的背面由托架鎖定。
  - 不要壓住或扭曲電源線。

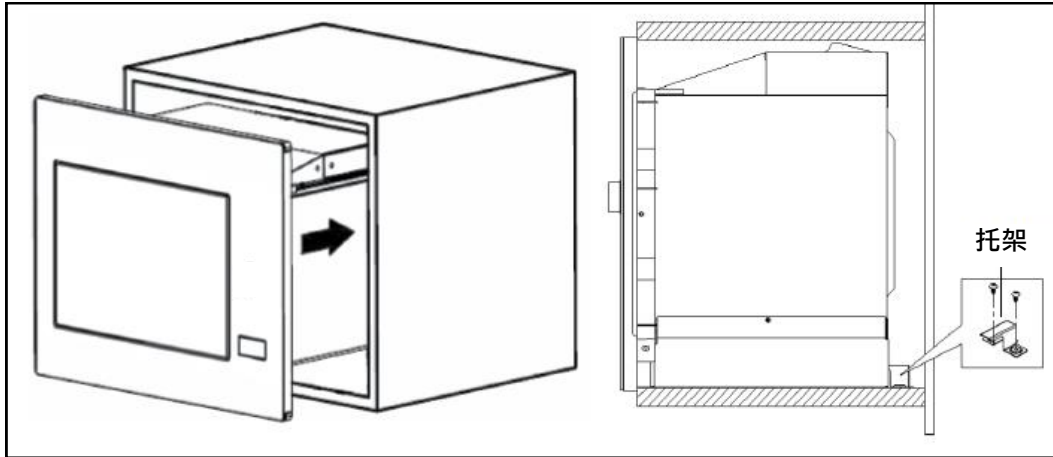

5. 打開爐門，用螺絲B將微波爐固定在櫥櫃上的安裝孔位置。

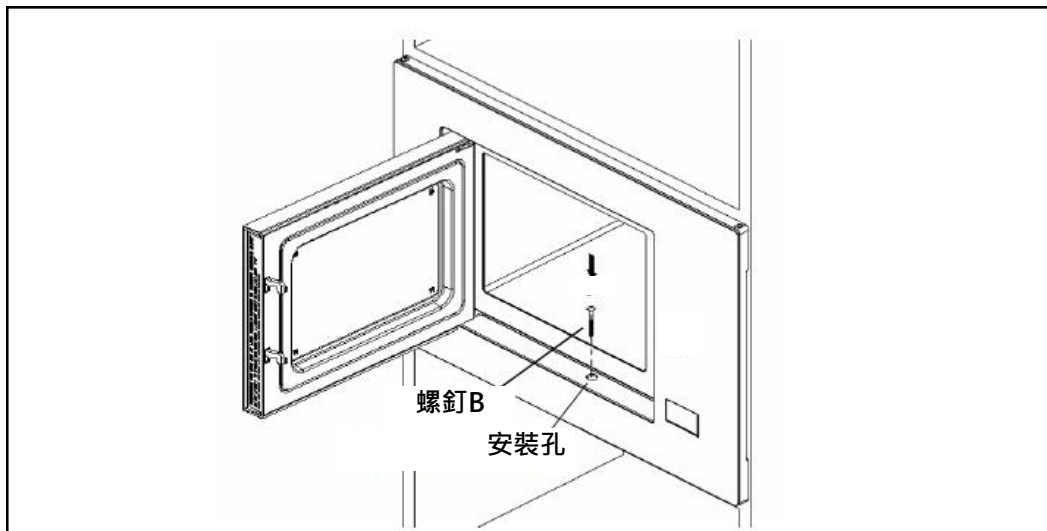

## 清潔及保養

請必須從電源插座上拔下產品插頭。

1. 使用稍微濕潤的布擦拭後，便可清潔爐腔。
2. 用正常方式，用肥皂水清潔配件。
3. 必須使用濕布，仔細清潔髒污的門框、密封氣及周圍的零件。
4. 請勿使用粗糙的研磨劑或鋒利的金屬刮刀來清潔爐門玻璃，因為它們可能會劃損玻璃表面，導致玻璃碎裂。
5. 清潔小技巧

為更簡單地清潔接觸到食物的爐壁：

將半個檸檬放入碗中，加入300ml ( 1/2品脫 ) 的水，並在100%微波火力下加熱10分鐘。

使用柔軟的乾布，把微波爐擦拭乾淨。

# 操作指示

## 1. 時鐘設定

當微波爐通電時，LED螢幕將顯示「0:00」，蜂鳴器響一聲。

- 1) 按「時鐘/預設」一次，小時數字將閃爍。
- 2) 轉動「選擇旋鈕」以調整小時數字，輸入的時間應在 0-23 之間。
- 3) 按「時鐘/預設」，分鐘數字將閃爍。
- 4) 轉動「選擇旋鈕」以調整分鐘數字，輸入的時間應在 0-59 之間。
- 5) 按「時鐘/預設」完成時鐘設定。「:」將閃爍，並且時間會發亮。

注意：1) 如時鐘尚未設定，通電後微波爐也未能運作。

2) 在時鐘設定過程中，如果按「停止/取消」，微波爐將自動返回前一個狀態。

## 2. 微波烹飪

按「微波/燒烤/混合」，LED將顯示「P100」。按「微波/燒烤/混合」數次或轉動「選擇旋鈕」來選擇您所需的火力，每多按一次，螢幕將顯示「P100」、「P80」、「P50」、「P30」或「P10」。然後按「開始/+30秒/確定」確認，並轉動「選擇旋鈕」設定烹飪時間從0:05至95:00。再按「開始/+30秒/確定」開始烹飪。

例子：如果要使用80%微波火力烹飪20分鐘，您可以按照以下步驟，操作微波爐。

- 1) 按「微波/燒烤/混合」一次，螢幕顯示「P100」。
- 2) 再按「微波/燒烤/混合」一次，或轉動「選擇旋鈕」選擇 80%微波火力。
- 3) 按「開始/+30秒/確定」確認，螢幕顯示「P80」。
- 4) 轉動「選擇旋鈕」調較烹飪時間，直到微波爐顯示「20:00」。
- 5) 按「開始/+30秒/確定」開始烹飪。

注意：編碼開關的時間調較步驟如下：

0--1分鐘	:	5秒
1--5分鐘	:	10秒
5--10分鐘	:	30秒
10--30分鐘	:	1分鐘
30--95分鐘	:	5分鐘

顯示次序	「微波/燒烤/混合」面板指令顯示	微波火力	燒烤火力
1	P100	100%	0%
2	P80	80%	0%
3	P50	50%	0%
4	P30	30%	0%
5	P10	10%	0%
6	G	0%	100%
7	C-1	55%	45%
8	C-2	36%	64%

## 3. 燒烤或混合烹飪

按「微波/燒烤/混合」一次，顯示「P100」後，按「微波/燒烤/混合」數次或轉動「選擇旋鈕」選擇您所需的火力。每多按一次，螢幕將顯示「G」、「C-1」或「C-2」。按「開始/+30秒/確定」確認，轉動「選擇旋鈕」設定烹飪時間從 0:05 至 95:00。再次按「開始/+30秒/確定」開始烹飪。

# 操作指示

例子：如果要使用55%的微波火力和45%的C-1燒烤火力烹飪10分鐘，您可以按照以下步驟操作微波爐。

- 1) 按「微波/燒烤/混合」一次，螢幕顯示「P100」。
- 2) 再按「微波/燒烤/混合」，或轉動「選擇旋鈕」選擇混合烹飪。
- 3) 按「開始/+30秒/確定」確認，螢幕顯示「C-1」。
- 4) 轉動「選擇旋鈕」調較烹飪時間，直到微波爐顯示「10:00」。
- 5) 按「開始/+30秒/確定」開始烹飪。

注意：如果燒烤（純燒烤）時間過了一半，微波爐會發出兩次聲音，這是正常現象。

為了獲得更好的燒烤效果，您應該把食物翻過來，關上爐門，然後按「Start/+30Sec./Confirm」繼續烹飪。如果沒有操作，微波爐將繼續烹飪。

## 4. 快速啟動

- 1) 在等候狀態下，按「開始/+30秒/確定」，用100%火力開始烹飪30秒，每多按一次，將增加30秒烹飪時間，直至95分鐘為止。
- 2) 微波爐上的燒烤、混合烹飪或解凍時間的功能，每按一次「開始/+30秒/確定」將增加30秒的烹飪時間。
- 3) 等候狀態下，轉動「選擇旋鈕」設定烹飪時間，使用100%微波火力，按「開始/+30秒/確定」開始烹飪。

## 5. 按重量解凍

- 1) 按「重量解凍/時間解凍」一次，微波爐顯示「dEF1」。
- 2) 轉動「選擇旋鈕」選擇食物重量為100至2000克。
- 3) 按「開始/+30秒/確定」開始解凍。

## 6. 按時間解凍

- 1) 按「重量解凍/時間解凍」兩次，微波爐顯示「dEF2」。
- 2) 轉動「選擇旋鈕」選擇解凍時間。
- 3) 按「開始/+30秒/確定」開始解凍。

## 7. 自動功能表

- 1) 轉動「選擇旋鈕」選擇功能表，螢幕顯示從「A-1」至「A-10」，這代表薄餅、肉類、蔬菜、義大利闊麵、馬鈴薯、魚、飲品和爆米花。
- 2) 按「開始/+30秒/確定」確認。
- 3) 轉動「選擇旋鈕」選擇功能表表中的預設重量。
- 4) 按「開始/+30秒/確定」開始烹飪。

例子：如果要使用「自動功能表」來烹飪350克的魚。

- 1) 轉動「選擇旋鈕」直到螢幕顯示「A-4」。
- 2) 按「開始/+30秒/確定」確認。
- 3) 轉動「選擇旋鈕」選擇魚的重量350g，直到螢幕顯示「350」。
- 4) 按「開始/+30秒/確定」開始烹飪。

# 操作指示

## 菜單表

菜單	重量	顯示
A-1 薄餅	200 克	200
	400 克	400
A-2 馬鈴薯	200 克	200
	400 克	400
	600 克	600
A-3 肉類	250 克	250
	350 克	350
	450 克	450
A-4 魚	250 克	250
	350 克	350
	450g	450
A-5 蔬菜	200 克	200
	300 克	300
	400 克	400
A-6 飲品	1杯 ( 120毫升 )	1
	2杯 ( 240毫升 )	2
	3杯 ( 360毫升 )	3
A-7 義大利闊麵	50 克 ( 含 450 克冷水 )	50
	100克 ( 含 800克冷水 )	100
A-8 爆米花	50 克	50
	100 克	100
A-9 雞	200 克	200
	400 克	400
	600 克	800
	800 克	600
A-10 再加熱	200 克	200
	400 克	400
	600 克	600

## 8. 廚房計時器

- 1) 按「時鐘/預設」一次，小時數字將閃爍。轉動「選擇旋鈕」以調整小時數字。
- 2) 按「時鐘/預設」，分鐘數字將閃爍。轉動「選擇旋鈕」以調整分鐘數字。
- 3) 按「開始/+30 秒/確定」確認設定。
- 4) 當達到廚房計時 ( 預定時間 ) 時，蜂鳴器將響鳴 5 次。如果時鐘已經設定 ( 24 小時制 )，LED 將顯示當前時間。

注意：廚房計時不同於 24 小時制。廚房計時是計時器。

## 9. 預設烹飪

- 1) 先設定時鐘 ( 請參考時鐘設定部份 )。
- 2) 設置烹飪程式。最多可設置 2 個烹飪程式。  
預設烹飪不應設置解凍程式。

# 操作指示

例子：如果要於預設時間使用80%微波火力烹飪7分鐘，您可以按照以下步驟，操作微波爐。

- 1) 按「微波/燒烤/混合」一次，螢幕顯示「P100」。
- 2) 再按「微波/燒烤/混合」一次，或轉動「選擇旋鈕」選擇 80%微波火力。
- 3) 按「開始/+30 秒/確定」確認，螢幕顯示「P80」。
- 4) 轉動「選擇旋鈕」調較烹飪時間至顯示「7:00」。完成以上步驟後不要按「開始/+30 秒/確定」開始烹飪。
- 5) 按「時鐘/預設」一次，小時數字將閃爍。
- 6) 轉動「選擇旋鈕」以調整小時數字，輸入的時間應在 0-23 之間。
- 7) 按「時鐘/預設」，分鐘數字將閃爍。
- 8) 轉動「選擇旋鈕」以調整分鐘數字，輸入的時間應在 0-59 之間。
- 9) 按「開始/+30 秒/確定」完成設置。爐門必須關閉。當到達預設時間，蜂鳴器響起 2 次後烹飪自動開始。

## 10. 多段烹飪

最多可設定2種階段的功能進行烹飪。在多段烹飪中，如果其中一段為解凍，就先在第一段進行解凍。

例子：如果要解凍食物5分鐘，然後使用80%微波火力烹飪7分鐘，請按以下步驟操作：

- 1) 按「重量解凍/時間解凍」兩次，微波爐顯示「dEF2」。
- 2) 轉動「選擇旋鈕」選擇解凍時間，直到螢幕顯示「5:00」。
- 3) 按「微波/燒烤/混合」一次，螢幕顯示「P100」。
- 4) 再按「微波/燒烤/混合」一次或轉動「選擇旋鈕」選擇 80%微波火力。
- 5) 按「開始/+30 秒/確定」確認，螢幕顯示「P80」。
- 6) 轉動「選擇旋鈕」調較烹飪時間，直到微波爐顯示「7:00」。
- 7) 按「開始/+30秒/確定」開始烹飪，蜂鳴器將在第一段烹飪時，發出一聲聲音，顯示解凍時間倒計時開始；當進入第二段烹飪時，蜂鳴器會再次響起。完成烹飪後，蜂鳴器會響5次。

## 11. 功能查詢

- 1) 在微波爐上，對於燒烤或混合烹飪的功能，按「微波/燒烤/混合」，螢幕將顯示現時的火力 3 秒鐘。3 秒鐘後，微波爐將返回到前一個狀態。
- 2) 在烹飪狀態下，按「時鐘/預設」查詢時間，螢幕將顯示時間 3 秒鐘。
- 3) 在廚房計時狀態下，按「時鐘/預設」查詢計時器設定時間，螢幕將顯示時間 3 秒鐘。

## 12. 兒童鎖定功能

**鎖定：**在等候狀態下，按「停止/取消」3秒鐘，會有長嗶聲，表示進入兒童鎖定狀態。

如已設定時間，LED螢幕則會顯示當時時間，否則LED螢幕會顯示「**---**」。

**解鎖：**在鎖定狀態下，按「停止/取消」3秒鐘，將有長嗶聲，表示已解鎖。

## 13. 規範

- 1) 如果在烹飪過程中打開爐門，必須按「開始/+30 秒/確定」才可繼續烹飪。
- 2) 設定烹飪程式後，若 1 分鐘內沒有按「開始/+30 秒/確定」，螢幕將顯示當時時間。設定將被取消。
- 3) 按動有效，將使蜂鳴器響一次，按動無效，則不會有任何反應。
- 4) 當完成烹飪時，蜂鳴器將發出 5 次提醒。

# 疑難排解

## 正常

微波爐干擾電視接收信號	當微波爐運作時，收音機和電視的接收信號，可能受到干擾。它的干擾類似一般小型電器，如攪拌器、真空吸塵器和電風扇。這是正常現象。
爐燈昏暗	在使用低火力微波烹飪時，爐燈可能會變得昏暗。這是正常現象。
蒸汽集聚在爐門上，熱氣從通風口排出	烹飪時，食物也許會散發蒸汽，大部分蒸汽都會從通風口排出，但也有部分蒸汽會積聚在爐門等涼爽的地方。這是正常現象。

## 禁止

在爐內沒有食物的情況下，意外啟動微波爐。	爐內沒有食物的情況下，禁止使用微波爐。這是十分危險。
----------------------	----------------------------

## 疑難

問題	可能原因	解決方法
無法啟動微波爐	(1) 電線未插緊。	拔下插頭，10秒後重新插上。
	(2) 保險絲熔斷或漏電斷路器正在操作。	更換保險絲或重設斷路器（由本公司專業人員進行維修）。
	(3) 插座故障。	使用其他電器測試插座。
微波爐無法加熱	(4) 爐門未妥善關閉。	妥善關閉爐門。
微波爐運作時，玻璃轉盤發出噪音	(5) 轉盤托架和微波爐底部太骯髒。	參考「微波爐保養」一節來清潔骯髒的部分。

## 客戶服務中心

在尋求協助前請先進行上述檢查。如您無法識別操作異常的原因，請關閉設備（不要對其進行不當處理），並聯繫服務中心。

## 產品序號位置

您應該可通知服務中心有關產品代碼及其序列號（16字符代碼，以3開頭）。有關資料可在保養卡或產品規格牌上找到。



本產品根據歐洲廢電子電機設備（WEEE）2002/96/EC 指令進行標記。通過確保正確處理本產品，您將有助防止對環境和人體健康造成潛在的負面影響，不當處理廢棄本產品有可能造成潛在的負面影響。產品上的符號表示該產品可能不被視為生活垃圾。棄置時須將其移至適合的廢電氣電子設備回收收集點處置，並須按當地有關廢物處理的環境法例執行。

有關更多本產品的處理、重用和回收的詳細信息，請聯繫您當地的市政府、家庭廢物處理服務或您購買產品的商店。



*Mia Cucina*  
KITCHENS BY TOWNGAS